



Install Guide

Crucial® Adrenaline Solid State Cache Solution

NOTE: DATAPLEX™ SOFTWARE IS IN ENGLISH ONLY.

Introduction

Comprising a 50GB Crucial m4 SSD, a 3.5" adapter bracket, and Dataplex™ software, Crucial Adrenaline Solid State Cache solution intelligently manages how the SSD and hard drive interact. By placing, or "caching," the most frequently needed files on the SSD and keeping less frequently used files on the hard drive, you get the best of both worlds: SSD-like performance and the existing capacity of your hard drive.

Once installed, the Dataplex software combines your existing hard drive and the solid state cache into a single storage system. Dataplex is fully automated, runs in the background, and requires no user management.

To get started, follow these steps:

1. Add the Crucial Solid State Cache to your PC system
2. Download the Dataplex software from www.crucial.com/support/registeradrenaline
3. Install the Dataplex software using the Setup Wizard

System Requirements

In order to run Dataplex properly, your computer must meet the following system requirements:

Operating System

- Microsoft® Windows® 7

Storage

- 1 (or more) SATA Hard Disk Drive(s) and
- 1 Crucial Adrenaline Solid State Drive

Storage Controllers (One of the following)

- Microsoft AHCI controller
- Intel RAID controller
- Intel AHCI controller
- AMD AHCI controller
- Legacy IDE controller

Restrictions and Limitations

Dataplex software has the following restrictions:

- DO NOT detach your hard drive (target drive) or solid state drive (cache drive) while Dataplex is enabled. Doing so puts you at risk of losing data and/or rendering your machine unbootable. If you need to detach or swap a drive UNINSTALL Dataplex first.
- DO NOT detach your hard drive (target drive) and put it into another SATA port while Dataplex is enabled. Doing so puts you at risk of losing data and/or rendering your machine unbootable. If you need to switch SATA ports, UNINSTALL Dataplex first.

Dataplex software has the following limitations:

- Only one cache drive (SSD) is supported in a system.
- There cannot be two identical SSDs in the system, one of which is to be used as cache.
- The target drive (hard drive) must be the primary boot drive running Windows 7. GPT (GUID Partition Table) partitions are not supported.
- There is no support for target drives (hard drives) larger than 2TB in capacity.
- Uninstall of Dataplex software must be done through the Control Panel. Uninstalling from the install.exe file is not supported.
- If after uninstalling Dataplex the system is restored to prior state in which Dataplex was installed, Dataplex will be started in a disabled state.

Hardware Installation

Before installing the Dataplex software your PC must have the following devices installed properly:

- Target Drive: The target drive is your hard disk drive and is where the Windows operating system is installed.

- Cache Drive: The cache drive is the Solid State Drive (SSD) which is used by the Dataplex software as a cache. No applications are installed or files saved by the user to the cache drive.

NOTE: The following instructions assume your hard disk drive (target drive) is installed and functioning properly. For information about your hard disk drive, refer to the manufacturer's documentation.

Precautions

Electronic components are fragile and very sensitive to static electricity. To protect you and your system, take the following precautions:

- Turn off power to the computer and disconnect power cable.
- Wear a wrist strap and connect the ground strap to the computer.
- DO NOT touch the connectors.
- DO NOT open the drive enclosure.

Installation Steps

Note: Refer to your PC system manual for details about your specific system.

1. Remove the case cover from your PC system.
2. Using a SATA cable, attach one end of the cable to the SATA connector on your motherboard. Attach the other end of the SATA cable to the SSD.

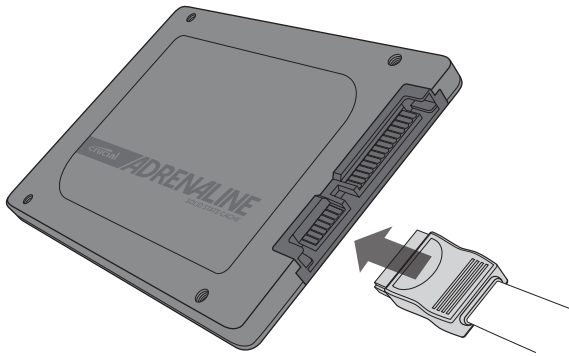

3. Using the available SATA power cable coming from your power supply, connect cable to the SSD.

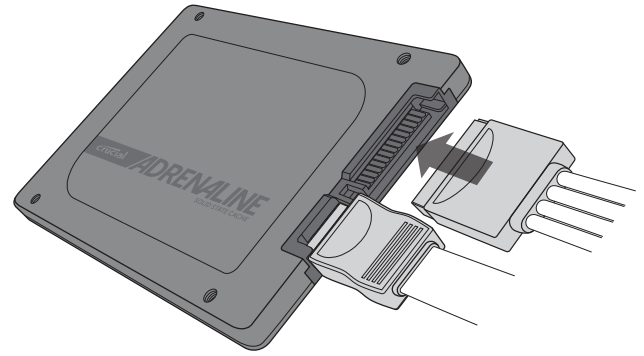

4. Mount and secure the SSD in an open drive bay. If required, use bracket to adapt the 2.5" SSD to fit into a 3.5" drive bay.

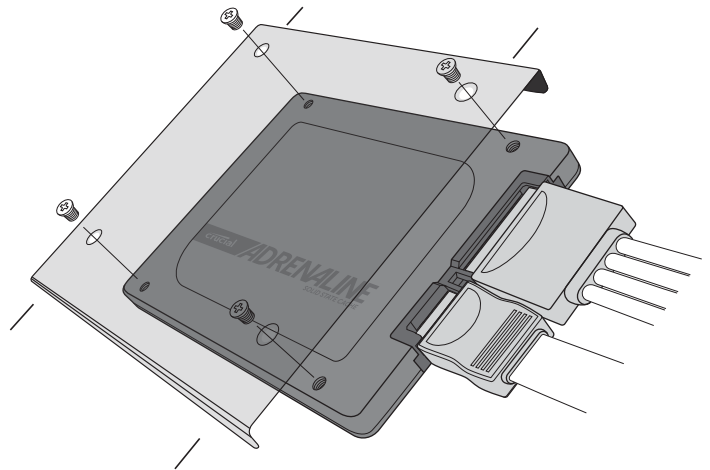

5. Close the case.

NOTE: Firmware updates enable your solid state drive to deliver the best performance. To check for the most current available firmware please go to: www.crucial.com/ssdfirmware. It is highly recommended you update your firmware prior to software installation.

Dataplex Software Download and Installation

After your Target Drive and Cache Drive are installed properly you may download and install the Dataplex software. To download the Dataplex software visit:

www.crucial.com/support/registeradrenaline

WARNING: All data on the SSD will be deleted during the software installation process.

Prerequisites:

- You MUST have Administrator privileges for your PC system.
- You MUST be connected to the internet to complete the installation process.

Follow these steps to install the Dataplex software:

1. Extract the Dataplex software package.
2. Right-click on the "install.exe" file and choose "Run as Administrator"
3. The Dataplex Setup Wizard will appear, click "Next" to continue.
4. Read the End-User License Agreement. Click in the checkbox next to "I accept..." then click "Next" to continue.
5. Enter the License Key provided in the Dataplex Software License Key card provided with the Crucial Adrenaline packaging. Note that if you input your

Product Key during the Dataplex software registration/download process, your Product Key is also available in the Thank You email.

6. Select the Target Drive (hard drive) and Cache Drive (SSD), click "Next" to continue.
7. Confirm the Target Drive (hard drive) and Cache Drive (SSD). **WARNING:** All data on the SSD will be deleted during the software installation process. After confirmation, click "Next" to continue.
8. Click "Install" to begin the installation.
9. After installation is complete a Completed the Dataplex Setup Wizard screen will appear, click "Finish".
10. To enable Dataplex, reboot your system.

To verify your installation:

1. From the Windows Start Menu, select "All Programs"
2. Locate the Dataplex folder, click on the folder to expand.
3. Select "Dataplex Status", the status field will state ENABLED.

crucial.com/support/ssd

©2012 Micron Technology, Inc. All rights reserved. Information is subject to change without notice. Crucial and the Crucial logo are trademarks or registered trademarks of Micron Technology, Inc. All other trademarks and service marks are property of their respective owners. Products and specifications are subject to change without notice. Neither Crucial nor Micron Technology is responsible for omissions or errors in typography or photography.